

PORTABLE LINE BORING AND WELDING MACHINE



INDIBORER - YANTRA WELD

SPECIFICATION :

Item	TLPBW50A Boring and welding integrated
Voltage	220 V
Max.diameter of boring hole	55-280
length of boring bar	1500/2000/2500
Spindle movement	290
Maximum turning amount	2
Driver system	servo motor
Motor power	1.8
The spindle speed	0-170
Feed amount	5
The range of feed speed	0-80
Torque	76.4
The surface roughness	3.2
Boring roundness error	0.02
The support structure	screw
The range of milling	55-230



HEAD OFFICE :

PATHAK INDUSTRIES KOL

a unit of T.L. PATHAK GROUP

116,117,G.T. ROAD,SALKIA,HOWRAH-711106



8895929247



info@pathak.in



www.tlpathakgroup.com

PORTABLE LINE BORING AND WELDING MACHINE

STANDARD ACCESSORIES :



Tool



Insulation Sleeve



Nylon Sleeve Center



Tool Holder



Boring Bar



Screw



Welding Rod



Front and Rear Fixed Seat



Tool Bar

OPTIONAL ACCESSORIES : Drawing Of Machine :



Welding Tip



Face Milling



Dioxide Welding Machine Working Component Set

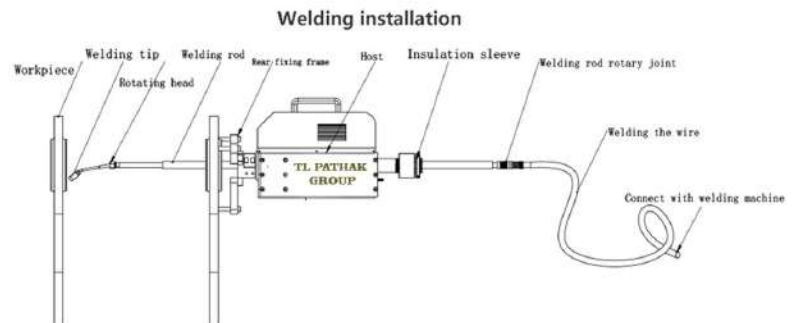
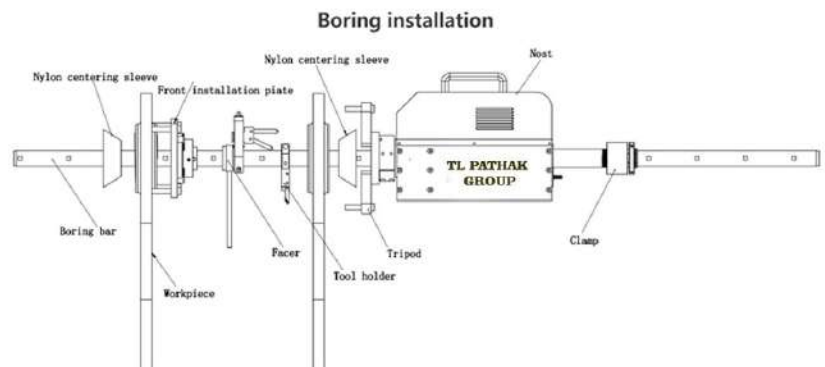

HEAD OFFICE :

PATHAK INDUSTRIES KOL

a unit of T.L. PATHAK GROUP

116,117,G.T. ROAD,SALKIA,HOWRAH-711106



8895929247



info@pathak.in



www.tlpathakgroup.com